



- Take Control of Your Sound -

Audio MusiKraft First Series LOMC (low output moving coil) phono cartridges

## Owner's Manual

\* Read this manual before handling the cartridge \*

This manual is for general information and applies to all Audio MusiKraft First Series Cartridges.

*- The World's First and Only "Tunable" and "Customizable" Phono Cartridge -*

*Note: The wood species is per customer's preference / l'essence de bois est au choix du client*





- Take Control of Your Sound -

Audio MusiKraft would like to thank you for purchasing this fine piece of audio equipment! We took a lot of pride in manufacturing it from start to finish. Get ready for the dramatic change and to

- Take Control of your Sound -

## INDEX

[General Warnings](#)

[Limitation of Warranty](#)

[Introduction](#)

[Features and Innovations](#)

[Included in the Kit](#)

[How to Use](#)

1. [Mounting on tonearm](#)
2. [Adjusting stylus pressure](#)
3. [Output voltage](#)
4. [Motor removal and installation](#)
5. [Tone wood inserts](#)
6. [Tuning screws](#)
7. [Proposed voicing procedure](#)

[Specifications](#)

[Options](#)

[Wood Species Selection Chart](#)

[Downloads](#)

[Our Word](#)



- Take Control of Your Sound -

## General Warnings:

- Always leave the cartridge guard on when the cartridge is not in use. We suggest you use it as the MusiKraft cartridges are more manipulated than any other cartridge in relation to their tuning capability.
- The cartridge is equipped with a magnet, so always keep steel tools or parts far from it.
- The cartridge is delicately constructed to maintain maximum performance. When the cartridge is handled, make certain that no under force is applied to the stylus. Do not drop it or move the stylus with a finger tip.
- If there is dust on the stylus when a record is played, the stylus tip cannot accurately trace the sound groove of the record, resulting in not only poor reproduction but also premature wear of the stylus and records. Remove dust with the supplied soft brush, carefully working from the root of the cantilever toward the stylus tip i.e. from back to front like the normal record rotation direction. Do not use liquid cleaners on the stylus.
- Dust on the record surface should be wiped away with a high quality cleaner. If cleaner containing moisture is used, allow the record surface to dry before playing.
- Even though our metallic shells are very rugged, on the three micro-tuning setscrews, use common sense when applying torque. So do not over tighten as a broken thread caused by over tightening isn't covered by warranty.
- Do not try to remove the wood inserts without in the first place removing the cartridge motor from the shell as you may damage the sensitive wires or cantilever (refer to our [video tutorials](#) page on how to add/remove these).
- Be careful not to dent the wood surface with finger nails when mounting or removing the inserts.
- In the event you need to clean the Audio MusiKraft shell, only clean with very soft damped cloth when the cartridge motor and the tone wood inserts are removed from its shell. Treat this piece of equipment as if it was jewelry and it will last you a lifetime.

## Limitation of Warranty:

Warranty: From the date of purchase Audio MusiKraft warrants their manufactured goods for **one (1) year** against defect in materials and craftsmanship only. The warranty does not cover any damage by the owner. Please handle your **First Series** cartridge carefully.

Claims on defective products do not apply to products which have been subject to misuse (including static discharge), neglect, accident, modification, or products which have been soldered or altered during assembly or are not capable of being tested. For eligibility, the cartridge must return to the manufacturer for inspection and approval.

Refer to our [Terms & Conditions](#) page for more details.



- Take Control of Your Sound -

## Introduction:

The Audio MusiKraft **First Series** high performance stereo phono cartridge is a - low output moving coil - type. It is a fully modular and recyclable concept in a unique precisely-machined two (2) part housing design - top plate and base- which at first sight allows for quick generator servicing or interchangeability. The shell (body) assembly is built to accept three (3) small pieces of either wood species or other upgradable material inserted within our numerous metalized structured shells of varying weight and finishes. In addition, three (3) micro-setscrews - two (2) lateral and one (1) frontal - to control mechanical resonance allowing delicate fine-tuning of the cartridges *interpretation* of certain sonic parameters; in effect permitting personal voicing of the final system sound or *satisfaction* control. Thirdly, the top plate of the housing complies with EIA standards with ten (10) threaded holes instead of the usual two (2), thus providing ample setup possibilities without the need of displacing the tonearm for proper overhang. The sharp-edge squarish profile and face are also a deliberate decision to ease the setup with strong visual cues, for proper visual VTA and azimuth alignment. The concept is particularly well suited for unlimited aftermarket upgrades.

## Features and Innovations:

- Fully modular design for interchange between motor, shell, and wood at your will
- Tonality and resonance controllable system
- Three (3) voicing fine-tuning micro setscrews
- Sharp perimeter edges for trouble-free cartridge installation and alignment
- Five (5) different geometric positions for overhang adjustment
- Straightforward to service: i.e. quick phono cartridge and wood insert installation (as for parts renewal or simply for swapping)
- Wide front clearance for stylus ease of view
- Highly durable and recyclable cartridge and shell
- All cartridge parts are very precisely machined ( $\pm 0.001"$ )
- Upgradable part options (motor, many wood species, finish and more)
- Almost infinite sonic tuning capability.

## Included in the Kit:

One (1) Audio MusiKraft phono cartridge  
One (1) 3D printed black plastic guard  
One (1) wood insert set (of your choice)  
One (1) M0.7mm Allen hex key  
One (1) miniature Philips screwdriver  
One (1) wooden pushrod tool for (wood insert removal)  
One (1) stylus brush  
One (1) pair M2.5 x 3mm, SS 304, Philips Pan Head screws;  
One (1) jewel box

Note: Each cartridge are electrically tested before leaving the factory

## How to Use:

### 1. Mounting on tonearm

- a) The MusiKraft can be mounted on any commercially available universal tonearm or headshell built to ½" EIA standards. In order to obtain the best performance from the cartridge, it is important to select a well constructed medium to high mass (10g or more) tonearm, and a solid headshell which both offers good performance. Additionally, this tonearm will require the ability to counterbalance at least 11g cartridges (refer to [MusiKraft specifications](#) for the exact cartridge weight).
- b) The overhang dimension of a tonearm differs from brand to brand. Adjust the position of the stylus to the specified overhang dimension of your tonearm. For simplicity, the MusiKraft shell cover offers five (5) different overhang positions. When the cartridge is mounted on the arm, be careful to prevent misalignment.
- c) The Audio MusiKraft shell cover measures 2.4mm thick and for a safe penetration, we recommend using the mounting screws which will penetrate between 1mm to 2.2mm (no less/no more) into the MusiKraft shell cover. Ignoring to follow proper length may cause damage to the hole threads and/or the shell base. Choose accordingly from the screw kit. If you need to compensate between lengths, the shims (flat washers) are 0.5mm thick. [Fig. 1](#).

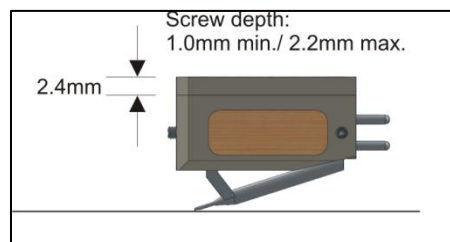

[Figure 1 Screw depth requirements](#)

- d) To protect the stylus tip, ensure that the cartridge is mounted on the arm with the stylus guard attached. Once mounted, you can remove the guard for ease of alignment.
- e) Vertical Tracking Angle (VTA). Adjust the height of the tonearm so that the cartridge is parallel to the record surface to be played. [Fig. 2](#)

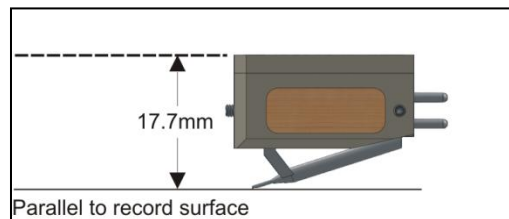

[Fig. 2 Vertical Tracking Angle \(VTA\)](#)

- f) Adjust the horizontal inclination (azimuth) of the cartridge so that the shell's cartridge sharp side edges and their reflection on a record surface (or by using a mirror) form straight and coincident lines or are perpendicular to the record surface. [Fig.3](#)

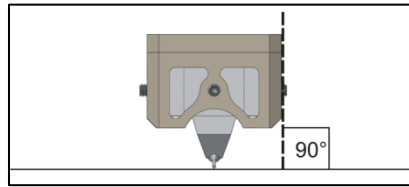

Fig. 3 Azimuth alignment (front view)

- g) The output terminals are arranged as shown in Fig. 4. Insert the output terminals of the cartridge in the lead tips of the head shell. The leads are colored or coded for identification. Make the correct connections.

**Caution:** If the output terminals of the cartridge are heated with a soldering iron, internal open circuit can result. Be sure to use lead tips.

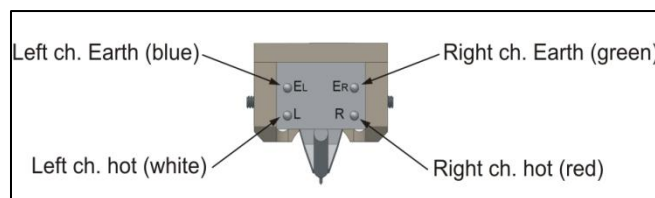

Fig. 4 Arrangement of output terminals (rear view)

## 2. Adjusting stylus pressure

Also known as the Vertical Tracking Force (VTF). The optimum stylus pressure is  $2.5 \text{ g.} \pm 0.3 \text{ g.}$  In the case of an unwarped record in good condition, the stylus pressure may be reduced to 2.2 gr. For a record made at a high recording level or when played under a low ambient temperature, the stylus pressure should be increased to 2.8 g. maximum. Generally, the individual characteristics of the cartridge have been determined at an ambient temperature of 20°C or thereabouts. Of course, the cartridge may be used over a wide temperature range, but you will obtain the best reproduction if you use it at the standard temperature or its vicinity.

**Caution:** Note that if an iron turntable platter is used, an excessive stylus pressure might be applied due to magnetic attraction.

## 3. Output voltage

The output voltages are 0.30 mV (DL-103) and 0.25mV (DL-103R). Since these are low relative to an MM type cartridge, your system must have a MC phono input or you will either need a MC Head amp or a step-up transformer (SUT).

#### 4. Motor removal and installation ([click for a short animated video of the assembly](#))

Our cartridge design was well thought out for servicing and part swapping. We suggest you to view our videos. Removing the motor from the shell is quite straightforward, installation also. Refer to [Fig. 5](#) for an exploded view.

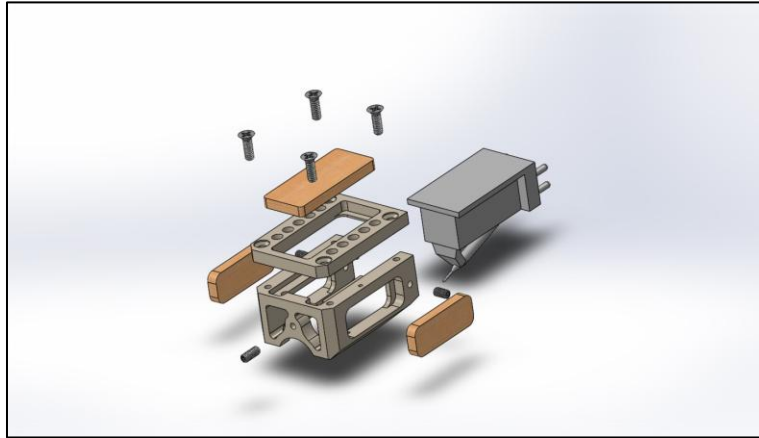

Fig. 5 Exploded view of cartridge

**Caution:** Be careful not to lay your fingers on the side of motor when retrieving it out of the shell or during manipulations as the very fine wires are exposed.

Removing the motor: ([video supported help](#))

- Lay a white paper sheet on your flat working area (this serves as a clean and bright work surface)
- To free up the motor, first remove the tension on the lateral tuning-screws which could later block the motor from being pulled out.
- Unscrew and remove the four (4) flat headed Philips cover screws
- By hand, remove the cover by pulling it upwards. The cover tongue and groove securely holds it in place.
- Flip the cartridge upside down on a flat surface (keep a finger on the motor's back while doing this so it doesn't fall out of the shell)
- Slide out the motor from the shell

Installing the motor: ([video supported help](#))

- Motor installation is the reversed procedure

#### 5. Tone wood inserts

The modular Audio MusiKraft design renders the inserts interchangeable within all the **First Series** cartridge models. Each insert set contains (3) three pieces; one (1) piece for the cover and two (2) for the sides.

Our cartridge design was well thought out for servicing and part swapping. We strongly suggest you to [view our particular videos about this section](#) as to familiarize yourself with our good practices. Removing the inserts from the shell is quite straightforward, as is for their installation. They are mechanically held in place by friction and are tight fitted from factory. The insert's edges are taper profiled so to eliminate the risk of chipping and for the ease of installation and removal. Your cartridge



- Take Control of Your Sound -

kit includes a tone wood set. In the event that you would like to go deeper into your tonal explorations we offer many more insert options as aftermarket parts which you can find in our [web store](#). Or on special order if you require more exotic woods or finish. If in need, we can guide you to make wise choices.

#### Wood species and their finish:

First of all, there are no perfect sounding woods and neither finishes. Each has different characteristics which may be sympathetic to one cartridge setup or detrimental in another. Secondly, ones interpretation of “good sound” varies between individuals; each person listens differently and has their own sonic preferences. The global result also depends on which equipment it is matched to. Throughout many listening test over the years while developing the MusiKraft shell we clearly noticed varying sonic signatures from the different alloys, motors, woods, finishes, and tuning-screw settings inherent to our cartridges. The MusiKraft concept allows thousands of combinations. Of course we haven't tried all of them but among some we were able to extrapolate relative information from our findings so to help you choose promising combinations.

Our three (3) external wood surface protectants:

- The Beeswax patina is used as surface preservation and to give color richness to the appearance. Our beeswax treatment is insignificant to changing the sound.  
Recommended application: once per year.
- Our numerous listening tests showed us that our lacquer coating is more than favorable when the time comes to add a tad bit more edge, dryness and impact to sound.
- The thorough natural oil treatment on tone woods serves as a wood resonance dampener. It adds a bit of tone in the sound. It also slightly darkens the background, and softens top end balance. Recommended application: per year.
- Side note: For sonic exploration while using our oil treatment, we recommend purchasing two (2) identical wood sets in case you would like to roll back as this test is irreversible.

**Caution:** 1. - The motor must always be removed from the shell when doing such change. 2. - Be careful not to lay your fingers on the side of motor when retrieving it out of the shell or during manipulations as very fine wires are exposed. 3. - Be careful not to dent the external wood surface with your finger nail.

Removing the wood inserts: ([video supported help](#))

- a) To free up the motor, first remove the tension on the lateral tuning-screws which could later block the motor from being pulled out.
- b) Unscrew and remove the four (4) flat headed Philips cover screws
- c) By hand, remove the cover by pulling it upwards. The cover tongue and groove securely holds it in place.
- d) Flip the cartridge upside down on a flat surface (keep a finger on the motor's back while doing this so it doesn't fall out of the shell)
- e) Slip out the motor
- f) With the help of the wooden pushrod, apply pressure on the edge of the internal surface of the top insert so it comes out.
- g) Proceed with the sides.



## Installing the wood inserts:

- a) Work with an empty shell (without the motor in place)
- b) Lay the wood insert flat and parallel to the shell pocket
- c) Apply even pressure with your thumb until the insert is all the way in and flush to the outer surface (**caution** with your finger nails). Confirm that it is well seated on both its internal beds.
- d) Proceed as well with the following two inserts.
- e) To free up the motor, first remove the tension on the lateral tuning-screws which could later block the motor from being pulled out.

## 6. Tuning Screws ([video supported help](#))

There are three (3) strategically positioned micro-setscrews; two (2) laterals and one (1) frontal control mechanical resonances by linking the shell at key areas on the motor. These allow delicate fine-tuning of the cartridges interpretation of certain sonic parameters. The sonic footprint is different between the laterals and the front screw as for the applied torque. One can activate the screws independently or vary the torque upon each. **Caution:** 1. - the purpose of these screws is not meant for maintaining the motor in place. 2. - Observe maximum recommended torque below. 3. - Only adjust the setscrews while your tonearm is in its rest position.

We suggest you to try three settings; no contact on motor, slightly in contact, and the suggested 1/8 turn (front) or 1/4 turn (lateral) depending on the setscrew. Use the provided M0.7mm Allen hex key (the small one) for adjusting.

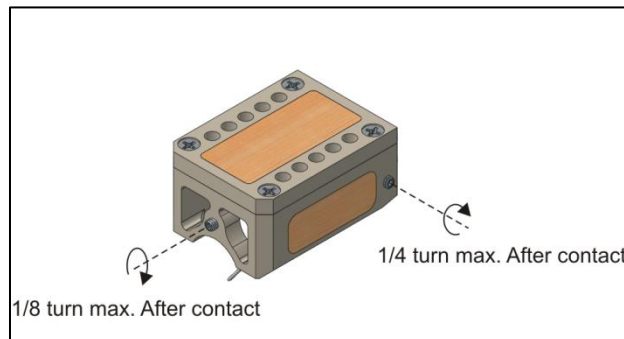

Fig. 4 Tuning Screws max. settings

## 7. Proposed voicing procedure

Here is a simple four (4) step procedure on how we suggest you to proceed on finding the best performance out of your cartridge. You are free to use it, i.e. it is not an absolute way to work.

Be rigorous, this is fine-tuning at its best. You will notice that the fine cartridge generator is very sensitive to its surrounding Audio MusiKraft shell tuning combinations. During your A/B comparisons, do not change the volume position, find a comfortable level from start and leave it as is. Changing it will impact your perception. Try different records before assuming the change will mirror itself in every type of music and recording. Use the same records for reliable conclusions. A good advice is to take notes while doing each listening steps as many sonic changes will occur. It may be long, but very rewarding at the end.



- Take Control of Your Sound -

- 1) Listen to the cartridge with the shell in a nude state:
  - a) Without wood inserts, nor tuning screws engaged
  
- 2) Listen to the cartridge in a nude state (without wood inserts, with screws engaged):
  - a) Engage rear screws with very slight contact with cartridge
  - b) Engage rear screws with slight pressure on the cartridge (1/4 turn max., once in slight contact)
  - c) Disengage rear screws
  - d) Engage front screw with very slight contact on pole piece
  - e) Engage front screw with slight pressure on the pole piece (1/8 turn max., once in slight contact)
  
- 3) Listen to the cartridge with wood inserts (without any screws engaged):
  - a) Switch between the different wood species. (**Caution:** at each wood change (swap), the cartridge must be removed from the shell).

If you opted for the oil treatment, here are two recommendations on how we proceed. In an increasing order, step b) then c) can be considered as two tuning settings:

- b) Slight oil test: In the bundle of wood insert sets you have tested; choose one that you found the most desirable. (A double of the wood set is advised as you won't be able to roll-back once the treatment has been done). Spread one pass of oil on the inside portion of the three (3) inserts covering the whole surface. Wait 1 hour. With a clean cotton rag, remove excess oil. Let sit for 24 hours in ventilated area so the small portion of natural solvent evaporates. Remove the remaining oil right before installation. Install the wood inserts on the shell and then the cartridge motor. Listen. If you tend to like the oil effect, proceed with step
- c) Saturated oil test: Still using this particular wood set, spread oil on all sides; immerse oil by repeating three times the process during 2 hours. Again, with a cotton rag remove excess oil. Let sit for 24 hours in ventilated area so the natural solvent evaporates. Remove the remaining oil right before installation. Install the wood inserts on the shell and then the nude Denon cart. Listen. Repeat if necessary to explore with other wood types.

**Note:** If you choose the oil treated version, we recommend refreshing the treatment **each (1) year** by adding a small drop on each wood insert (inside face). Once again, do this process with the cartridge motor removed from the shell.

- 4) Listen now to the cartridge with your preferred wood inserts (natural or with treatment / finish):
  - a) Choose preferred wood set and dial-in your preferred screw setting
  - b) Fine-tune screws to your sonic preference

## Specifications:

Series:	Aluminum (Al)		Lithium (Li)	
	DL-103	DL-103R	DL-103	DL-103R
Motor model:				
<b>Shell specifications:</b>				
Alloy material:	aluminum		lithium	
Protective layer:	anodized		paste seal	
Finish:	brushed, anodic oxide		mirror / hand polished	
Color:	clear or champagne		natural	
Shell weight (nude):	4.1g		3.9g	
Headshell mount:	per EIA Standards, 1/2"		per EIA Standards, 1/2"	
Shell cover threads:	10 - M2.5 x 0.45 (5 overhang positions)		10 - M2.5 x 0.45 (5 overhang positions)	
Cover depth clearance:	2.2mm (max. screw length)		2.2mm (max. screw length)	
Tone wood Inserts (1 set incl.):	Per you request		Per you request	
<b>Cartridge specifications:</b>				
Generating system:	LOMC (low output moving coil)		LOMC (low output moving coil)	
Channels:	2, stereo		2, stereo	
Cartridge size (LxWxH):	28.5 x 18.0 x 17.7mm		28.5 x 18.0 x 17.7mm	
Cartridge weight (with wood inserts):	11.7g - 12.2g		11.5g - 12.0g	
Coil conductor:	copper	6N pure copper	copper	6N pure copper
<b>Diamond:</b>				
Stylus shape:	conical		conical	
Tracking tip size:	0.65 mil		0.65 mil	
Cantilever:	light alloy		light alloy	
<b>Measurements:</b>				
Playback frequency response:	20-45,000 Hz		20-45,000 Hz	
Channel separation (1 kHz):	> 25 dB		> 25 dB	
Channel sensitivity difference (1 kHz):	< 1 dB		< 1 dB	
Output voltage (1 kHz, 50mm/sec.):	0.30 mV	0.25 mV	0.30 mV	0.25 mV
Stylus pressure (vertical tracking force):	2.5 ± 0.3 g		2.5 ± 0.3 g	
Compliance (on disc):	5 x 10 <sup>-6</sup> cm/dyne		5 x 10 <sup>-6</sup> cm/dyne	
Electrical impedance (1 kHz):	40Ω ± 20 %	14Ω ± 20 %	40Ω ± 20 %	14Ω ± 20 %
Recommended load resistance:	100Ω min. (40 Ω min. SUT)	100Ω min. (14Ω min. SUT)	100Ω min. (40 Ω min. SUT)	100Ω min. (14Ω min. SUT)

	Magnesium (Mg)		Bronze Gold (BrG)	
	DL-103	DL-103R	DL-103	DL-103R
Series:				
Motor model:				
<b>Shell specifications:</b>				
Alloy material:	magnesium		bronze	
Protective layer:	passivated coating		14k gold	
Finish:	matte / iridescent		mirror / hand polished	
Color:	olive green		gold	
Shell weight (nude):	2.8g		13.1g	
Headshell mount:	per EIA Standards, 1/2"		per EIA Standards, 1/2"	
Shell cover threads:	10 - M2.5 x 0.45 (5 overhang positions)		10 - M2.5 x 0.45 (5 overhang positions)	
Cover depth clearance:	2.2mm (max. screw length)		2.2mm (max. screw length)	
Tone wood Inserts (1 set incl.):	Per your request		Per your request	
<b>Cartridge specifications:</b>				
Generating system:	LOMC (low output moving coil)		LOMC (low output moving coil)	
Channels:	2, stereo		2, stereo	
Cartridge size (LxWxH):	28.5 x 18.0 x 17.7mm		28.5 x 18.0 x 17.7mm	
Cartridge weight (with wood inserts):	10.4g - 10.9g		20.6g - 21.1g	
Coil conductor:	copper	6N pure copper	copper	6N pure copper
<b>Diamond:</b>				
Stylus shape:	conical		conical	
Tracking tip size:	0.65 mil		0.65 mil	
Cantilever:	light alloy		light alloy	
<b>Measurements:</b>				
Playback frequency response:	20-45,000 Hz		20-45,000 Hz	
Channel separation (1 kHz):	> 25 dB		> 25 dB	
Channel sensitivity difference (1 kHz):	< 1 dB		< 1 dB	
Output voltage (1 kHz, 50mm/sec):	0.30 mV	0.25 mV	0.30 mV	0.25 mV
Stylus pressure (vertical tracking force):	2.5 ±0.3 g		2.5 ±0.3 g	
Compliance (on disc):	5 x 10 <sup>-6</sup> cm/dyne		5 x 10 <sup>-6</sup> cm/dyne	
Electrical impedance (1 kHz):	40Ω ± 20 %	14Ω ± 20 %	40Ω ± 20 %	14Ω ± 20 %
Recommended load resistance:	100Ω min. (40 Ω min. SUT)	100Ω min. (14Ω min. SUT)	100Ω min. (40 Ω min. SUT)	100Ω min. (14Ω min. SUT)

Series:	<b>Bronze Collector's (BrC)</b>	
Motor model:	<b>DL-103</b>	<b>DL-103R</b>
<b>Shell specifications:</b>		
Alloy material:	bronze	
Protective layer:	micro-crystalline wax	
Finish:	authentic patina	
Color:	6 choices	
Shell weight (nude):	13.1g	
Headshell mount:	per EIA Standards, 1/2"	
Shell cover threads:	10 - M2.5 x 0.45 (5 overhang positions)	
Cover depth clearance:	2.2mm (max. screw length)	
Tone wood Inserts (1 set incl.):	Per your request	
<b>Cartridge specifications:</b>		
Generating system:	LOMC (low output moving coil)	
Channels:	2, stereo	
Cartridge size (LxWxH):	28.5 x 18.0 x 17.7mm	
Cartridge weight (with wood inserts):	20.6g - 21.1g	
Coil conductor:	copper	6N pure copper
<b>Diamond:</b>		
Stylus shape:	conical	
Tracking tip size:	0.65 mil	
Cantilever:	light alloy	
<b>Measurements:</b>		
Playback frequency response:	20-45,000 Hz	
Channel separation (1 kHz):	> 25 dB	
Channel sensitivity difference (1 kHz):	< 1 dB	
Output voltage (1 kHz, 50mm/sec.):	0.30 mV	0.25 mV
Stylus pressure (vertical tracking force):	2.5 ± 0.3 g	
Compliance (on disc):	5 x 10 <sup>-6</sup> cm/dyne	
Electrical impedance (1 kHz):	40Ω ± 20 %	14Ω ± 20 %
Recommended load resistance:	100Ω min. (40 Ω min. SUT)	100Ω min. (14Ω min. SUT)

## Options:

Additional wood inserts or other accessories.

## Wood Species Selection Chart (name/density/hardness):



<p>1.- Birdseye Maple/Érable piqué 705-6450</p> <p>2.- Pignut Hickory (pale)/Caryer glabre (pâle) 835-9520</p> <p>3.- Pignut Hickory (dark)/Caryer glabre (foncé) 835-9520</p> <p>4.- Curly Maple/Érable ondulé 705-6450</p> <p>5.- Black Walnut/Noyer noir 610-4490</p> <p>6.- Black Cherry/Cerisier 560-4230</p>	<p>7.- Cumaru 1085-14800</p> <p>8.- Shagbark Hickory/Noyer blanc 800-8360</p> <p>9.- Ipe 1100-15620</p> <p>10.- Jatoba 910-11950</p> <p>11.- Lime/Tilleul 415-1824</p> <p>12.- Maple/Érable 705-6450</p>
--	--



<p>13.- Mahogany/Acajou 640-4760</p> <p>14.- Northern White Cedar/Cèdre 350-1420</p> <p>15.- White Pine/Pin blanc 400-1690</p> <p>16.- Poplar (green &amp; yellow avail.)/Peuplier 455-2400</p> <p>17.- Red Alder/Aulne 450-2620</p> <p>18.- Red Cedar/Cèdre de l'Ouest 370-1560</p>	<p>19.- Torrefied Ash/Frêne torréfié 675-5870</p> <p>20.- Torrefied Birch/Merisier torréfié 690-5610</p> <p>21.- Teak/Teck 655-4740</p> <p>22.- Torrefied Pine/Pin torréfié 400-1690</p> <p>23.- Claro Walnut/Noyer de Californie 640-5030</p> <p>24.- White Oak/Chêne blanc 755-5990</p>	<p><b>Notes:</b></p> <p>1.- Shown stock samples are slightly oiled</p> <p>2.- density (kg/m<sup>3</sup>) - Janka hardness (N)</p> <p>3.- Due to the natural variations in wood grain, their aspect may vary</p> <p>4.- Overall colors may vary depending on your screen settings</p>
--	---	--

www.audiomusikraft.com

\*Take in consideration:

Due to the natural variations in wood grain, its aspect may vary and overall colors may vary depending on your screen settings.

For best fitment, we suggest buying your extra wood sets at cartridge or shell's date of purchase.

## Downloads:

[Common Wood Inserts List and Pictures \(24 species\)](#) (PDF)

[Complete Wood Inserts Pricelist and Density Chart \(100 species\)](#) (PDF)



- Take Control of Your Sound -

## Our Word:

In the event you have a question, we invite you to consult our [FAQ's page](#), or to [contact us](#) for more specific questions.

We hope these instructions will help you get the best out of your cartridge.

We would greatly appreciate receiving your feedback and thanks in advance for sharing your experience with other enthusiasts.

All the Best,

Audio MusiKraft